

Operation and Service Manual

AC Resistance Bridge

SIM921



Stanford Research Systems

Revision 1.45 • June 29, 2004

Certification

Stanford Research Systems certifies that this product met its published specifications at the time of shipment.

Warranty

This Stanford Research Systems product is warranted against defects in materials and workmanship for a period of one (1) year from the date of shipment.

Service

For warranty service or repair, this product must be returned to a Stanford Research Systems authorized service facility. Contact Stanford Research Systems or an authorized representative before returning this product for repair.

Information in this document is subject to change without notice.

Copyright © Stanford Research Systems, Inc., 2003, 2004. All rights reserved.

Stanford Research Systems, Inc.
1290-C Reamwood Avenue
Sunnyvale, CA 94089 USA
Phone: (408) 744-9040 • Fax: (408) 744-9049
www.thinkSRS.com • e-mail: info@thinkSRS.com

Printed in U.S.A.



Contents

General Information	iii
Service	iii
Symbols	iv
Notation	v
Specifications	vi
1 Getting Started	1-1
1.1 Introduction to the Instrument	1-2
1.2 Front-Panel Operation	1-3
1.3 Sensor Interface	1-8
1.4 SIM Interface	1-10
2 Remote Operation	2-1
2.1 Index of Commands	2-2
2.2 Alphabetic List of Commands	2-4
2.3 Introduction	2-7
2.4 Commands	2-8
2.5 Status Model	2-21

General Information

The SIM921 AC Resistance Bridge, part of Stanford Research Systems' Small Instrumentation Modules family, is a precision, high-sensitivity instrument designed for ultra-low power resistance measurements, typically for cryogenic thermometry.

Service

Do not install substitute parts or perform any unauthorized modifications to this instrument.

The SIM921 is a double-wide module designed to be used inside the SIM900 Mainframe. Do not turn on the power until the module is completely inserted into the mainframe and locked in place.

Symbols you may Find on SRS Products

Symbol	Description
	Alternating current
	Caution - risk of electric shock
	Frame or chassis terminal
	Caution - refer to accompanying documents
	Earth (ground) terminal
	Battery
	Fuse
	On (supply)
	Off (supply)

Notation

The following notation will be used throughout this manual:

- Front-panel buttons are set as [Button];
[Adjust ▲▼] is shorthand for “[Adjust ▲] & [Adjust ▼]”.
- Front-panel indicators are set as *Overload*.
- Remote command names are set as *IDN?.
- Literal text other than command names is set as OFF.

Specifications

Performance Characteristics

Measurement	Measurement type	4 wire AC bridge
	Number of inputs	1
	Resistance range	1 m Ω to 100 M Ω
	Time constant	0.3 s to 300 s, or sync. only
	Reading rate	2 updates/s
	Demodulator resolution	32-bit
	Resolution	see table
	Accuracy (% reading + % range)	
	2 Ω to 200 k Ω , $\geq 30 \mu\text{V}$, $\geq 3 \text{nA}$	$\pm(0.05 \% + 0.05 \%)$
	200 m Ω to 2 M Ω , $\geq 100 \text{pA}$	$\pm(0.15 \% + 0.15 \%)$
	Stability	
	after autocal	$(\pm 0.001 \% \text{ of reading})/^{\circ}\text{C}$
	without autocal	$(\pm 0.02 \% \text{ of reading})/^{\circ}\text{C}$
	Max. lead resistance	100 Ω + 25 % range
Input impedance	> 10 G Ω , typical	
Source	Type	Sinusoid, constant I, V , or P
	Frequency	2 Hz to 60 Hz, continuously adjustable
	Excitation	3 μV to 30 mV, 10 mA max.
	Max. DC current	< 3 μV /range
Thermometry	Sensors supported	All resistive sensors (– and + tempco)
	Temperature units	mK, K
	Low temperature	~50 mK, sensor dependent
	Sensor cal. curves	3 curves of 200 points each
Analog Output	Range	$\pm 10 \text{V}$
	Resolution	300 μV
	Accuracy	1 mV
Operating	Temperature	0 $^{\circ}\text{C}$ to 40 $^{\circ}\text{C}$, non-condensing
	Interface	Serial via SIM interface
	Connectors	
	Sensor	DB–9 (female)
	Analog out	BNC (front)
	SIM	DB–15 (male) SIM Interface
	Power	$\pm 15 \text{VDC}$, +5 VDC
Supply current	150 mA ($\pm 15 \text{V}$), 250 mA (+5 V)	

Resolution

Resolution is given in the table below. Upper values give excitation current, while lower values are typical RMS resistance noise measured at 50 % full scale on a room-temperature resistor with a 3 second output time constant.

Range	Excitation								
	30 mV	10 mV	3 mV	1 mV	300 μ V	100 μ V	30 μ V	10 μ V	3 μ V
20 m Ω	N/A	N/A	N/A	N/A	N/A	10 mA	3 mA	1 mA	300 μ A
						44 $\mu\Omega$	130 $\mu\Omega$	510 $\mu\Omega$	1.5 m Ω
200 m Ω	N/A	N/A	N/A	10 mA	3 mA	1 mA	300 μ A	100 μ A	30 μ A
				8.9 $\mu\Omega$	12 $\mu\Omega$	32 $\mu\Omega$	120 $\mu\Omega$	590 $\mu\Omega$	1.4 m Ω
2 Ω	N/A	10 mA	3 mA	1 mA	300 μ A	100 μ A	30 μ A	10 μ A	3 μ A
		4.3 $\mu\Omega$	5.5 $\mu\Omega$	7.9 $\mu\Omega$	23 $\mu\Omega$	70 $\mu\Omega$	220 $\mu\Omega$	730 $\mu\Omega$	1.8 m Ω
20 Ω	3 mA	1 mA	300 μ A	100 μ A	30 μ A	10 μ A	3 μ A	1 μ A	300 nA
	20 $\mu\Omega$	21 $\mu\Omega$	33 $\mu\Omega$	41 $\mu\Omega$	100 $\mu\Omega$	390 $\mu\Omega$	1.7 m Ω	4.1 m Ω	10 m Ω
200 Ω	300 μ A	100 μ A	30 μ A	10 μ A	3 μ A	1 μ A	300 nA	100 nA	30 nA
	200 $\mu\Omega$	200 $\mu\Omega$	370 $\mu\Omega$	430 $\mu\Omega$	1.1 m Ω	2.8 m Ω	9.7 m Ω	25 m Ω	120 m Ω
2 k Ω	30 μ A	10 μ A	3 μ A	1 μ A	300 nA	100 nA	30 nA	10 nA	3 nA
	2.0 m Ω	2.0 m Ω	2.9 m Ω	4.0 m Ω	12 m Ω	40 m Ω	120 m Ω	300 m Ω	900 m Ω
20 k Ω	3 μ A	1 μ A	300 nA	100 nA	30 nA	10 nA	3 nA	1 nA	300 pA
	20 m Ω	25 m Ω	31 m Ω	56 m Ω	200 m Ω	640 m Ω	2.4 Ω	5.3 Ω	23 Ω
200 k Ω	300 nA	100 nA	30 nA	10 nA	3 nA	1 nA	300 pA	100 pA	30 pA
	250 m Ω	350 m Ω	640 m Ω	1.4 Ω	4.5 Ω	16 Ω	47 Ω	150 Ω	710 Ω
2 M Ω	30 nA	10 nA	3 nA	1 nA	300 pA	100 pA	30 pA	10 pA	3 pA
	3.4 Ω	5.9 Ω	16 Ω	46 Ω	190 Ω	480 Ω	1.7 k Ω	5.4 k Ω	15 k Ω
20 M Ω	3 nA	1 nA	300 pA	100 pA	30 pA	10 pA	3 pA	1 pA	300 fA
	50 Ω	190 Ω	540 Ω	1.1 k Ω	5.4 k Ω	12 k Ω	56 k Ω	180 k Ω	750 k Ω

General Characteristics

Interface	Serial (RS-232) through SIM interface
Connectors	DB-9 (female)
	AC 4-wire measurement + ground
	DB-15 (male) SIM interface
Weight	1.4 lbs
Dimensions	1.5" W \times 3.6" H \times 7.0" D

1 Getting Started

This chapter gives the user the necessary information to get started quickly with the SIM921 AC Resistance Bridge.

In This Chapter

1.1	Introduction to the Instrument	1-2
1.1.1	Overview	1-2
1.2	Front-Panel Operation	1-3
1.2.1	Resetting to factory defaults	1-3
1.2.2	Numeric display	1-3
1.2.3	Display	1-3
1.2.4	Range	1-5
1.2.5	Excite	1-6
1.2.6	Output	1-7
1.2.7	Autocal	1-7
1.3	Sensor Interface	1-8
1.3.1	Four-wire measurement	1-8
1.3.2	Two-wire measurement	1-9
1.3.3	Wiring for high impedance	1-9
1.4	SIM Interface	1-10
1.4.1	SIM interface connector	1-10
1.4.2	Direct interfacing	1-10

1.1 Introduction to the Instrument

The SIM921 AC Resistance Bridge monitors a single resistive sample—typically a cryogenic thermometer—with an adjustable AC current. With achievable excitation power below 100 aW, self-heating errors can be routinely eliminated.

1.1.1 Overview

The SIM921 uses a half-bridge topology, where the excitation current is passed through both an internal, stable reference resistor, R_R , and the user's resistive thermometer, R_M (see Figure 1.1). Eight separate reference resistors, from 1 Ω to 10 M Ω , are built into the instrument, with two expanded scales (200 m Ω and 20 m Ω) implemented with additional gain.

The basic measurement is made by a pair of dual-phase demodulators to recover the vector AC voltage (amplitude and phase) developed across the internal reference resistor, V_R and across the user's resistor under measurement, V_M . The SIM921 determines the user's resistance value ratiometrically from

$$R_M = \frac{|\mathbf{V}_M|^2}{\mathbf{V}_R \bullet \mathbf{V}_M} \times R_R$$

By taking the in-phase component of \mathbf{V}_R in the ratio, the measurement is largely insensitive to capacitive loads in parallel with the R_M ; the phase shift they introduce is corrected in the denominator.

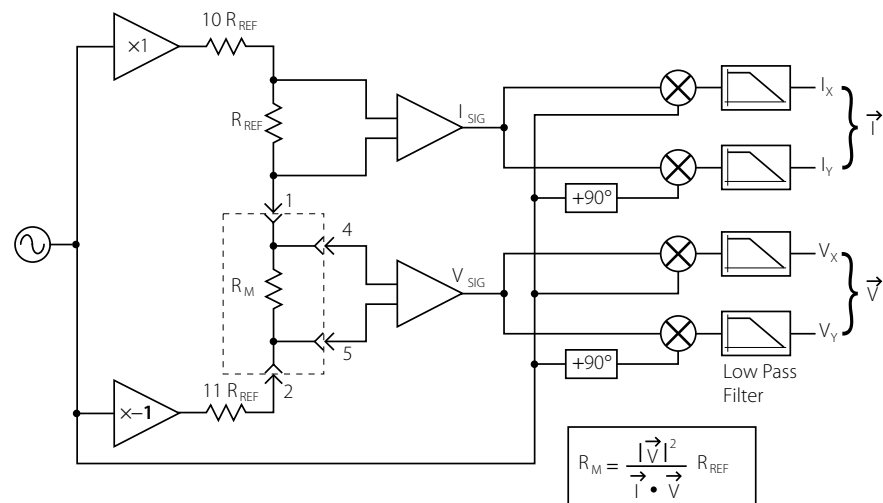

Figure 1.1: Block diagram of the SIM921.

1.2 Front-Panel Operation

The front panel of the SIM921 is divided into several major functional blocks, each of which will be discussed.



Figure 1.2: The SIM921 front panel.

1.2.1 Resetting to factory defaults

To reset the SIM921 to factory defaults, hold [Set ▲] depressed while turning power on to the module. This is equivalent to the remote command *RST.

1.2.2 Numeric display

The upper block of the front panel is the numeric display field. In addition to 5 1/2 digits, six units LEDs ($m\Omega$, Ω , $k\Omega$, $M\Omega$, mK , and K) indicate the physical units of the quantity displayed. The two buttons to the left of the numeric display, [Set ▲▼], allow the user to modify settable parameters.

1.2.3 Display

Directly beneath [Set ▲▼] is the DISPLAY block of the panel. The two buttons at the bottom of this section, [Display ▲▼], select the quantity for display in the numeric field.

The selections are:

Value : The measured value of the user’s resistor-under-test is displayed, either in resistance units or temperature units (depending on the units selection, below).

When *Value* is displayed, pressing [Set ▼] acts as a short-cut to reset the output filter. This can be useful to speed settling with a long time constant after a large resistance change is made, or after the range or excitation is changed.

Value–Offset : This selection (also known as “deviation”) also displays the measurement result (either in resistance or temperature units), but after subtracting the user-settable Offset. Pressing [Set ▼] will reset the output filter.

Phase (deg.) : This selection shows the phase angle between measured current and voltage (in degrees), and is an indication of how much capacitive loading is present. Phase is positive for capacitive loads. A phase angle near +90° should be viewed with caution: this indicates that most of the current is flowing through the reactive part of the load, and measurement accuracy may suffer.

When phase is displayed, [Set ▲▼] can be used to modify the model used in the SIM921 to determine resistance. By pressing [Set ▼], the numeric display will show the word: $\angle \epsilon r o$. This forces the meter to *assume* the phase angle between the voltage and current is zero when solving for R . This is helpful when measuring very small resistances (such as superconducting samples), since the phase determination becomes otherwise ill-conditioned when the voltage signal approaches zero, and causes excess noise in the results. Pressing [Set ▲] restores normal operation.

Offset : The offset, or setpoint, is the user-selected value to subtract from the sensor measurement. The offset is used in the *Value–Offset* display (above), as well as to determine the analog output voltage (see below). The [Set ▲▼] buttons will accelerate through multiple digits to adjust the offset; two short cuts also exist. If both [Set ▲] and [Set ▼] are pressed simultaneously, *Offset* is preloaded with the latest measurement result of *Value*. Depressing both buttons again will force *Offset* to zero.

Freq. (Hz) : This field controls the excitation frequency for the SIM921. [Set ▲▼] adjusts the frequency from 2 Hz to 60 Hz. Depressing both [Set ▲] and [Set ▼] together will step between 15 Hz, 10 Hz, 5 Hz, and 2.5 Hz.

A_{OUT} : This parameter is the slope (in V/ Ω or V/K) used to scale the deviation signal for analog output. Use [Set ▲▼] to accelerate through many orders of magnitude for A_{OUT} ; releasing the button and re-pressing it allows fine control over the lower digits, as the setting begins accelerating again. If resistance units are selected for analog output, the Ω indicator will be lit next to the numeric display; if temperature units are selected, the K indicator will be lit.

Units (Ω , K): This is actually three separate selections that are stepped through by continuing to press [Display ▲▼]. The first selection lights both the *Value* and *Units* indicators. This selects either resistance or temperature units for the *Value* display. Use [Set ▲▼] to switch between resistance (the display will show $r \text{ } \Omega$) and temperature (the display will show the ID message of the selected sensor calibration curve).

Pressing [Display ▼] again will light A_{OUT} and *Units* together. Now, [Set ▲▼] selects between resistance or temperature units for the analog output function. Note that the deviation display and offset parameter units are also determined by A_{OUT} -*Units*.

Pressing [Display ▼] one final time will leave *Units* lit alone. Now the [Set ▲▼] selects among three sensor calibration curves stored in the SIM921. If a particular curve has not been loaded, the \sim is lit to indicate this is not a usable curve; once (at least) two points are loaded in a sensor curve memory, the display will show \ast to the left of the curve ID. Only one curve can be selected at a time.

1.2.4 Range

The RANGE block of the front panel selects the reference resistor. Press [Range ▲▼] to step between ranges from 20 m Ω to 20 M Ω . For all ranges $\geq 2 \Omega$, the reference resistor R_R is 1/2 the total range. For example, on the 20 k Ω range, $R_R = 10 \text{ k}\Omega$. For ranges $\leq 2 \Omega$, the $R_R = 1.0 \Omega$.

The Autorange subblock controls two independent functions related to range. Briefly tapping [Autorange] will toggle autorange *Display* on and off. When *Autorange Display* is off, the numeric display decimal point is fixed based on the selected range. With *Autorange Display* on, the decimal point (and possibly the units indicator) shifts to display the result with maximum resolution.

Holding [Autorange] for ~ 2 seconds light *Gain* and initiate an auto-gain cycle. Whenever the SIM921 is set to a new range or excitation, the internal amplifiers are preset to nominal gains. This might not be

optimal for measuring resistors that are much smaller than, or larger than, the nominal range setting. Also, if the user is in a high-noise environment, out-of-band pick-up might cause amplifier saturation. In either of these cases, initiating an autogain cycle will force the SIM921 to optimize gains *for the signals present at that time*. Once completed, the *Gain* is unlit, and the amplifier gains remain fixed at their new levels. Changing excitation or range will reset the amplifiers to their (new) nominal settings.

1.2.5 Excite

The EXCITE block controls the excitation amplitude for the measurement. [Excite ▲▼] step between excitation levels in 1–3–10 steps from 3 μV to 30 mV. It is possible to step the amplitude setting down once more from the 3 μV setting, setting the excitation amplitude to zero. Note that this does not close the shunting relay, as On/Off does (below).

The amplitude, together with the excitation mode, determines the actual conditions for the measurement. [Mode], at the bottom of the EXCITE block, is another dual-function control. Briefly tapping [Mode] toggles the excitation On/Off; when Off, a mechanical relay shunts the excitation current, preventing any current from flowing to the user's resistor.

While the excitation is off, holding [Mode] for ~ 2 seconds will step between four (4) distinct excitation modes:

- Constant Current : With *Current* lit, the SIM921 will operate in constant current mode. This programs an AC current with rms amplitude of excite/R_R ; for example, if the excitation is set to 100 μV and the range is 20 k Ω , the excitation current will equal 10 nA (100 μV / 10 k Ω = 10 nA). This is implemented by servoing the measured voltage *across the reference resistor*, R_R to the selected excitation amplitude.
- Constant Voltage : With *Voltage* lit, the SIM921 will operate in constant voltage mode. In this mode, the excitation is servoed to keep the measured voltage *across the user's resistor*, R_M equal to the selected excitation. This can be particularly useful for negative tempco thermometers at low temperatures, where a constant current would lead to increasing power dissipation at lower temperatures ($P = I^2 R_M$, $R_M \uparrow$, $P \uparrow$ as $T \downarrow$). With constant voltage, the ohmic dissipation goes down with decreasing temperature ($P = V^2/R_M$, $R_M \uparrow$, $P \downarrow$ as $T \downarrow$).
- Constant Power : With both *Current* and *Voltage* lit, the SIM921 servoes the excitation to keep the power dissipated in the user's resistor

constant, at the level $V^2/(R_R/2)$.

Passive : With neither indicator lit, the SIM921 disables excitation servoing, and simply sets a fixed AC amplitude across the entire bridge circuit. The amplitude is set so that for R_M up to about the $2R_R$, the current will approximately equal the corresponding constant-current setting (above). For user resistances much larger than the range setting ($R_M \gg R_R$), the voltage across the user resistor will approach $\sim 20\times$ the nominal excitation (see Figure 1.1).

1.2.6 Output

The OUTPUT block of the front panel selects the post-detection filter setting, and contains the BNC connector for the analog output. The filter is a simple 6 dB/octave low pass filter that calculates a running exponential average of the vector voltages (prior to the ratio calculation). Higher settings of the time constant will reduce measurement noise at the expense of slower settling times. The filter affects the display values as well as the analog output voltages.

[Time Const. ▲▼]step the filter time constant in 1–3–10 steps from 0.3 s to 300 s. Stepping the time constant downwards from 0.3 s turns off the 6 dB/octave filter completely, leaving only a running boxcar “sync” filter (that averages the signals over the one excitation period) active. The sync filter effectively eliminates the $2 \times f$ signals from the demodulator output, but otherwise provides little noise reduction. This is an appropriate setting for relatively high signal-to-noise measurements where signal bandwidth is important.

It can take six or seven time constants for the output of the SIM921 to fully settle after a step change; for slow time constant settings, this can be a bothersome delay. The filter can be reset by pressing [Set ▼] when the display is *Value* or *Value–Offset*.

1.2.7 Autocal

The AUTOCAL block controls the internal autocalibration of the SIM921. Autocalibration cross-calibrates the relative gain of the two amplifier chains in the system. The process takes about three (3) minutes to complete, and can be started by holding [Autocal] for ~ 2 seconds. A countdown is displayed to indicate approximate time remaining. The autocalibration can be aborted by pressing [Autocal] again before the cycle completes—this will abandon the calibration in progress, and revert to the previous calibration values.

1.3 Sensor Interface

The sensor interface on the SIM921 consists a rear-panel DB-9/F connector, labeled “INPUT” (see Figure 1.3). The pin assignments for this connector are given in Table 1.1.

Pin	Signal
1	I+ (current lead)
2	I- (current lead)
3	ground
4	V+ (voltage lead)
5	V- (voltage lead)
6	ground
7	ground
8	ground
9	ground

Table 1.1: SIM921 Sensor Interface Connector Pin Assignments, DB-9

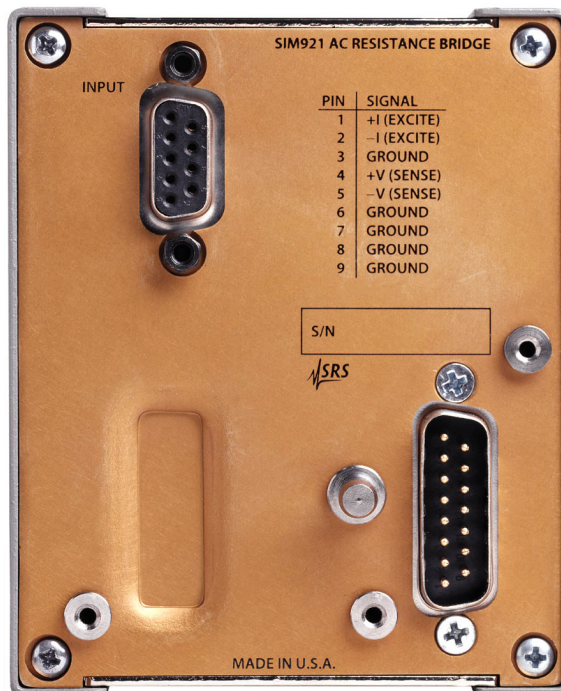

Figure 1.3: The SIM921 rear panel.

1.3.1 Four-wire measurement

To avoid sensitivity to wiring lead resistance, the SIM921 is configured for four-wire measurements. The basic circuit for this wiring

scheme is shown in Figure 1.4.

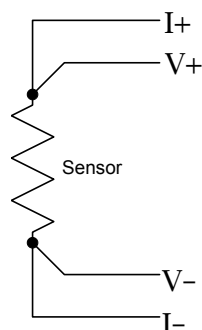

Figure 1.4: Wiring diagram for four-wire readout.

1.3.2 Two-wire measurement

If application-specific constraints limit the number of leads to the sensor, the SIM921 can be wired to measure the sensor resistance with a simple two-wire circuit, shown in Figure 1.5. Note that the lead resistance (past the junction points of the current and voltage leads) will add as a direct resistance error when measuring the sensor.

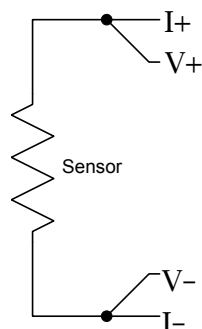

Figure 1.5: Wiring diagram for two-wire readout.

1.3.3 Wiring for high impedance

When using the SIM921 to measure high impedances ($>$ few $M\Omega$), cable construction becomes crucial. It is important that the wire leads have a low-loss dielectric insulation, such as PTFE (TeflonTM). Ordinary PVC-insulated wire is *not* well suited to this application, as it can suffer from dielectric absorption effects. Regardless of a very high DC insulation resistance ($>$ 100 $G\Omega$), small AC dielectric losses, even at the low frequencies used by the SIM921, can appear as (10s~100s) $M\Omega$ of *real* impedance in parallel with the user load.

1.4 SIM Interface

The primary connection to the SIM921 AC Resistance Bridge is the rear-panel DB-15 SIM interface connector. Typically, the SIM921 is mated to a SIM900 Mainframe via this connection, either through one of the internal mainframe slots, or the remote cable interface.

It is also possible to operate the SIM921 directly, without using the SIM900 Mainframe. This section provides details on the interface.

1.4.1 SIM interface connector

The DB-15 SIM interface connector carries all the power and communications lines to the instrument. The connector signals are specified in Table 1.2

Pin	Signal	Direction Src ⇒ Dest	Description
1	SIGNAL_GND	MF ⇒ SIM	Ground reference for signal
2	-STATUS	SIM ⇒ MF	Status/service request (GND=asserted, +5V=idle)
3	RTS	MF ⇒ SIM	HW Handshake (unused in SIM921)
4	CTS	SIM ⇒ MF	HW Handshake (unused in SIM921)
5	-REF_10MHZ	MF ⇒ SIM	10 MHz reference (optional connection)
6	-5V	MF ⇒ SIM	Power supply (No connection in SIM921)
7	-15V	MF ⇒ SIM	Power supply (analog circuitry)
8	PS_RTN	MF ⇒ SIM	Power supply return
9	CHASSIS_GND		Chassis ground
10	TXD	MF ⇒ SIM	Async data (start bit="0"=+5 V; "1"=GND)
11	RXD	SIM ⇒ MF	Async data (start bit="0"=+5 V; "1"=GND)
12	+REF_10MHZ	MF ⇒ SIM	10 MHz reference (optional connection)
13	+5V	MF ⇒ SIM	Power supply (digital circuitry)
14	+15V	MF ⇒ SIM	Power supply (analog circuitry)
15	+24V	MF ⇒ SIM	Power supply (No connection in SIM921)

Table 1.2: SIM Interface Connector Pin Assignments, DB-15

1.4.2 Direct interfacing

The SIM921 is intended for operation in the SIM900 Mainframe, but users may wish to directly interface the module to their own systems without the use of additional hardware.

The mating connector needed is a standard DB-15 receptacle, such as Amp part # 747909-2 (or equivalent). Clean, well-regulated supply voltages of +5, ±15 VDC must be provided, following the pin-out specified in Table 1.2. Ground must be provided on pins 1 and 8, with chassis ground on pin 9. The -STATUS signal may be monitored

on pin 2 for a low-going TTL-compatible output indicating a status message.

The SIM921 has no internal protection against reverse polarity, missing supply, or overvoltage on the power supply pins.

1.4.2.1 Direct interface cabling

If the user intends to directly wire the SIM921 independent of the SIM900 Mainframe, communication is usually possible by directly connecting the appropriate interface lines from the SIM921 DB-15 plug to the RS-232 serial port of a personal computer.¹ Connect RXD from the SIM921 directly to RD on the PC, TXD directly to TD, and similarly RTS→RTS and CTS→CTS. In other words, a null-modem style cable is *not* needed.

To interface directly to the DB-9 male (DTE) RS-232 port typically found on contemporary personal computers, a cable must be made with a female DB-15 socket to mate with the SIM921, and a female DB-9 socket to mate with the PC's serial port. Separate leads from the DB-15 need to go to the power supply, making what is sometimes know as a "hydra" cable. The pin-connections are given in Table 1.3.

DB-15/F to SIM921	Name
	DB-9/F
10 ↔ 3	TxD
11 ↔ 2	RxD
5	Computer Ground
	to P/S
7 ↔ -15 VDC	
14 ↔ +15 VDC	
13 ↔ +5 VDC	
8,9 ↔ Ground (P/S return current)	
1 ↔ Signal Ground (separate wire to Ground)	

Table 1.3: SIM921 Direct Interface Cable Pin Assignments

1.4.2.2 Serial settings

The serial port settings at power-on are: 9600 baud, 8-bits, no parity, 1 stop bit, and no flow control (see Section 2.3.1). The serial settings cannot be changed on the SIM921.

¹ Although the serial interface lines on the DB-15 do not satisfy the minimum voltage levels of the RS-232 standard, they are typically compatible with desktop personal computers

2 Remote Operation

This chapter describes operating the SIM921 over the serial interface.

In This Chapter

2.1	Index of Commands	2-2
2.2	Alphabetic List of Commands	2-4
2.3	Introduction	2-7
2.3.1	Power-on configuration	2-7
2.3.2	Buffers	2-7
2.3.3	Device Clear	2-7
2.4	Commands	2-8
2.4.1	Command syntax	2-8
2.4.2	Notation	2-9
2.4.3	Excitation commands	2-10
2.4.4	Measurement commands	2-11
2.4.5	Post-detection processing commands	2-13
2.4.6	Calibration curve commands	2-13
2.4.7	Autoranging commands	2-14
2.4.8	Autocalibration command	2-15
2.4.9	Setpoint and analog output commands	2-15
2.4.10	Interface commands	2-16
2.4.11	Status commands	2-19
2.5	Status Model	2-21
2.5.1	Status Byte (SB)	2-22
2.5.2	Service Request Enable (SRE)	2-23
2.5.3	Standard Event Status (ESR)	2-23
2.5.4	Standard Event Status Enable (ESE)	2-23
2.5.5	Communication Error Status (CESR)	2-24
2.5.6	Communication Error Status Enable (CESE)	2-24
2.5.7	Overload Status (OVCR)	2-25
2.5.8	Overload Status (OVSR)	2-25
2.5.9	Overload Status Enable (OVSE)	2-26

2.1 Index of Commands

symbol	definition
<i>i,j</i>	Integers
<i>f,g</i>	Floating-point values
<i>z</i>	Literal token
<i>s</i>	Arbitrary character sequence (no “,” or “;”)
(?)	Required for queries; illegal for set commands
<i>var</i>	Parameter always required
{ <i>var</i> }	Required parameter for set commands; illegal for queries
[<i>var</i>]	Optional parameter for both set and query forms

Excitation

FREQ(?) { <i>f</i> }	2 – 10	Frequency
RANG(?) { <i>i</i> }	2 – 10	Range
EXCI(?) { <i>i</i> }	2 – 10	Excitation
EXON? { <i>z</i> }	2 – 10	Excitation On/Off
MODE(?) { <i>z</i> }	2 – 11	Excitation Mode
IEXC?	2 – 11	Query Excitation Current
VEXC?	2 – 11	Query Excitation Voltage

Measurement

RVAL? [<i>i</i>]	2 – 11	Resistance Value
RDEV? [<i>i</i>]	2 – 11	Resistance Deviation
TVAL? [<i>i</i>]	2 – 11	Temperature Value
TDEV? [<i>i</i>]	2 – 12	Temperature Deviation
PHAS? [<i>i</i>]	2 – 12	Phase
TPER(?) { <i>i</i> }	2 – 12	Time Period for Streaming
SOUT	2 – 12	Stop Streaming
DISP(?) { <i>i</i> }	2 – 12	Display

Post-Detection

FRST	2 – 13	Filter Reset
TCON(?) { <i>i</i> }	2 – 13	Time Constant
PHLD(?) { <i>z</i> }	2 – 13	Phase Hold

CalCurves

DTEM(?) { <i>z</i> }	2 – 13	Display Temperature
ATEM(?) { <i>z</i> }	2 – 13	Analog Output Temperature
CURV(?) { <i>i</i> }	2 – 13	Sensor Calibration Curve
CINI(?) <i>i</i> { <i>z,s</i> }	2 – 14	Initialize Sensor Calibration
CAPT <i>i,f,g</i>	2 – 14	Add Point to Sensor Calibration
CAPT? <i>i,j</i>	2 – 14	Query Point in Sensor Calibration

Autorange

AGAI(?) {z}	2 – 15	Autorange Gain
ADIS(?) {z}	2 – 15	Autorange Display

Autocalibration

ACAL	2 – 15	Autocalibration
------	--------	-----------------

Setpoint/Analog Output

RSET(?) {f}	2 – 15	Resistance Setpoint
TSET(?) {f}	2 – 15	Temperature Setpoint
VOHM(?) {f}	2 – 15	Analog Output Scale (V/ Ω)
VKEL(?) {f}	2 – 15	Analog Output Scale (V/K)
AMAN(?) {z}	2 – 15	Analog Output Manual Mode
AOUT(?) {f}	2 – 16	Analog Output Manual Value

Interface

*RST	2 – 16	Reset
*IDN?	2 – 16	Identify
*TST?	2 – 16	Self Test
*OPC(?)	2 – 17	Operation Complete
CONS(?) {z}	2 – 17	Console Mode
LEXE?	2 – 17	Execution Error
LCME?	2 – 18	Command Error
LBTN?	2 – 18	Button
TOKN(?) {z}	2 – 19	Token Mode
TERM(?) {z}	2 – 19	Response Termination

Status

*STB? [i]	2 – 19	Status Byte
*SRE(?) [i,] {j}	2 – 19	Service Request Enable
*CLS	2 – 19	Clear Status
PSTA(?) {z}	2 – 20	Pulsed Status Mode
*ESR? [i]	2 – 20	Standard Event Status
*ESE(?) [i,] {j}	2 – 20	Standard Event Status Enable
CESR? [i]	2 – 20	Communication Error Status
CESE(?) [i,] {j}	2 – 20	Communication Error Status Enable
OVCR? [i]	2 – 20	Overload Condition
OVSR? [i]	2 – 20	Overload Status
OVSE(?) [i,] {j}	2 – 20	Overload Status Enable

2.2 Alphabetic List of Commands

★

*CLS	2 – 19	Clear Status
*ESE(?) [i,] {j}	2 – 20	Standard Event Status Enable
*ESR? [i]	2 – 20	Standard Event Status
*IDN?	2 – 16	Identify
*OPC(?)	2 – 17	Operation Complete
*RST	2 – 16	Reset
*SRE(?) [i,] {j}	2 – 19	Service Request Enable
*STB? [i]	2 – 19	Status Byte
*TST?	2 – 16	Self Test

A

ACAL	2 – 15	Autocalibration
ADIS(?) {z}	2 – 15	Autorange Display
AGAI(?) {z}	2 – 15	Autorange Gain
AMAN(?) {z}	2 – 15	Analog Output Manual Mode
AOUT(?) {f}	2 – 16	Analog Output Manual Value
ATEM(?) {z}	2 – 13	Analog Output Temperature

C

CAPT <i>i,f,g</i>	2 – 14	Add Point to Sensor Calibration
CAPT? <i>i,j</i>	2 – 14	Query Point in Sensor Calibration
CESE(?) [i,]{j}	2 – 20	Communication Error Status Enable
CESR? [i]	2 – 20	Communication Error Status
CINI(?) <i>i</i> {z,s}	2 – 14	Initialize Sensor Calibration
CONS(?) {z}	2 – 17	Console Mode
CURV(?) {i}	2 – 13	Sensor Calibration Curve

D

DISP(?) {i}	2 – 12	Display
DTEM(?) {z}	2 – 13	Display Temperature

E

EXCI(?) {i}	2 – 10	Excitation
EXON? {z}	2 – 10	Excitation On/Off

F

FREQ(?) {f}	2 – 10	Frequency
FRST	2 – 13	Filter Reset

I

IEXC? 2-11 Query Excitation Current

L

LBTN? 2-18 Button
 LCME? 2-18 Command Error
 LEXE? 2-17 Execution Error

M

MODE(?) {z} 2-11 Excitation Mode

O

OVCR? [i] 2-20 Overload Condition
 OVSE(?) [i,]{j} 2-20 Overload Status Enable
 OVSR? [i] 2-20 Overload Status

P

PHAS? [i] 2-12 Phase
 PHLD(?) {z} 2-13 Phase Hold
 PSTA(?) {z} 2-20 Pulsed Status Mode

R

RANG(?) {i} 2-10 Range
 RDEV? [i] 2-11 Resistance Deviation
 RSET(?) {f} 2-15 Resistance Setpoint
 RVAL? [i] 2-11 Resistance Value

S

SOUT 2-12 Stop Streaming

T

TCON(?) {i} 2-13 Time Constant
 TDEV? [i] 2-12 Temperature Deviation
 TERM(?) {z} 2-19 Response Termination
 TOKN(?) {z} 2-19 Token Mode
 TPER(?) {i} 2-12 Time Period for Streaming
 TSET(?) {f} 2-15 Temperature Setpoint
 TVAL? [i] 2-11 Temperature Value

V

VEXC? 2-11 Query Excitation Voltage
 VKEL(?) {f} 2-15 Analog Output Scale (V/K)

VOHM(?) {f}

2 – 15 Analog Output Scale (V/ Ω)

2.3 Introduction

Remote operation of the SIM921 is through a simple command language documented in this chapter. Both set and query forms of most commands are supported, allowing the user complete control of the amplifier from a remote computer, either through the SIM900 Mainframe or directly via RS-232 (see Section 1.4.2.1).

See Table 1.2 for specification of the DB-15 SIM interface connector.

2.3.1 Power-on configuration

The settings for the remote interface are 9600 baud with no parity and no flow control, and local echo disabled (CONS OFF).

Most of the SIM921 instrument settings are stored in non-volatile memory, and at power-on the instrument returns to the state it was last in when power was removed. Exceptions are noted in the command descriptions.

Reset values of parameters are shown in **boldface**.

2.3.2 Buffers

Incoming data from the host interface is stored in a 64-byte input buffer. Characters accumulate in the input buffer until a command terminator (either <CR> or <LF>) is received, at which point the message is parsed and executed. Query responses from the SIM921 are buffered in a 64-byte output queue.

If the input buffer overflows, then all data in *both* the input buffer and the output queue are discarded, and an error is recorded in the CESR and ESR status registers.

2.3.3 Device Clear

The SIM921 host interface can be asynchronously reset to its power-on configuration by sending an RS-232-style <break> signal. From the SIM900 Mainframe, this is accomplished with the SRST command; if directly interfacing via RS-232, then use a serial break signal. After receiving the Device Clear, the interface is reset to 9600 baud and CONS mode is turned OFF. Note that this *only* resets the communication interface; the basic function of the SIM921 is left unchanged; to reset the instrument, see *RST.

The Device Clear signal will also terminate any streaming outputs from the SIM921 due to a TVAL? or RVAL? query of multiple conversions.

2.4 Commands

This section provides syntax and operational descriptions for remote commands.

2.4.1 Command syntax

The four letter mnemonic (shown in **CAPS**) in each command sequence specifies the command. The rest of the sequence consists of parameters.

Commands may take either *set* or *query* form, depending on whether the “?” character follows the mnemonic. *Set only* commands are listed without the “?”, *query only* commands show the “?” after the mnemonic, and *optionally query* commands are marked with a “(?)”.

Parameters shown in { } and [] are not always required. Parameters in { } are required to set a value, and are omitted for queries. Parameters in [] are optional in both set and query commands. Parameters listed without any surrounding characters are always required.

Do *not* send () or { } or [] as part of the command.

Multiple parameters are separated by commas. Multiple commands may be sent on one command line by separating them with semicolons (;) so long as the input buffer does not overflow. Commands are terminated by either <CR> or <LF> characters. Null commands and whitespace are ignored. Execution of command(s) does not begin until the command terminator is received.

tokens Token parameters (generically shown as z in the command descriptions) can be specified either as a keyword or integer value. Command descriptions list the valid keyword options, with each keyword followed by its corresponding integer value. For example, to set the response termination sequence to <CR>+<LF>, the following two commands are equivalent:

TERM CRLF —or— TERM 3

For queries that return token values, the return format (keyword or integer) is specified with the TOKN command.

2.4.2 Notation

The following table summarizes the notation used in the command descriptions:

Symbol	Definition
i,j	Integers
f,g	Floating-point values
z	Literal token
s	Arbitrary character sequence (no “,” or “;”)
(?)	Required for queries; illegal for set commands
var	Parameter always required
{ var }	Required parameter for set commands; illegal for queries
[var]	Optional parameter for both set and query forms

2.4.3 Excitation commands

FREQ(?) {*f*} Frequency
 Set (query) the excitation frequency {to *f* Hz}.

RANG(?) {*i*} Range
 Set (query) the resistance range {to *i*}.

Valid range codes are:

<i>i</i>	Range
0	20 mΩ
1	200 mΩ
2	2 Ω
3	20 Ω
4	200 Ω
5	2 kΩ
6	20 kΩ
7	200 kΩ
8	2 MΩ
9	20 MΩ

EXCI(?) {*i*} Excitation
 Set (query) the nominal excitation {to *i*}.

Valid excitation codes are:

<i>i</i>	Excitation
-1	0 (excitation off)
0	3 μV
1	10 μV
2	30 μV
3	100 μV
4	300 μV
5	1 mV
6	3 mV
7	10 mV
8	30 mV

EXON? {*z*} Excitation On/Off
 Set (query) the excitation source {to *z*=(OFF 0 or ON 1)}.

MODE(?) {z}	Excitation Mode Set (query) the excitation mode {to z=(PASSIVE 0, CURRENT 1, VOLTAGE 2, POWER 3)}.
IEXC?	Query Excitation Current Query the actual excitation current amplitude, in amperes.
VEXC?	Query Excitation Voltage Query the actual excitation voltage amplitude, in volts.

2.4.4 Measurement commands

RVAL? [i]	Resistance Value Query the measured value of resistance, in ohms. If the optional <i>i</i> is specified, then <i>i</i> measurement results are returned to the host, separated by TPER milliseconds. If <i>i</i> =0 is specified, then streaming of RVAL? results continues indefinitely until the SOUT command is received.
RDEV? [i]	Resistance Deviation Query the measured value of resistance, in ohms, offset by the resistance setpoint (see RSET). If the optional <i>i</i> is specified, then <i>i</i> measurement results are returned to the host, separated by TPER milliseconds. If the optional <i>i</i> is specified, then <i>i</i> measurement results are returned to the host, separated by TPER milliseconds. If <i>i</i> =0 is specified, then streaming results continues indefinitely until the SOUT command is received.
TVAL? [i]	Temperature Value Query the measured value of temperature, in kelvin. If the optional <i>i</i> is specified, then <i>i</i> measurement results are returned to the host, separated by TPER milliseconds. If the optional <i>i</i> is specified, then <i>i</i> measurement results are returned to the host, separated by TPER milliseconds. If <i>i</i> =0 is specified, then streaming results continues indefinitely until the SOUT command is received.

TDEV? [<i>i</i>]	<p>Temperature Deviation</p> <p>Query the measured value of temperature, in kelvin, offset by the temperature setpoint (see TSET).</p> <p>If the optional <i>i</i> is specified, then <i>i</i> measurement results are returned to the host, separated by TPER milliseconds. If the optional <i>i</i> is specified, then <i>i</i> measurement results are returned to the host, separated by TPER milliseconds. If <i>i</i>=0 is specified, then streaming results continues indefinitely until the SOUT command is received.</p>																				
PHAS? [<i>i</i>]	<p>Phase</p> <p>Query the phase of the measured voltage (in degrees) with respect to the excitation current. Positive angles correspond to capacitive loads. This query disregards the PHLD setting.</p> <p>If the optional <i>i</i> is specified, then <i>i</i> measurement results are returned to the host, separated by TPER milliseconds. If the optional <i>i</i> is specified, then <i>i</i> measurement results are returned to the host, separated by TPER milliseconds. If <i>i</i>=0 is specified, then streaming results continues indefinitely until the SOUT command is received.</p>																				
TPER(?) { <i>i</i> }	<p>Time Period for Streaming</p> <p>Set (query) the time period {to <i>i</i>}, in ms. <i>i</i> must be no smaller than 100, and no greater than 655350. <i>i</i> must also be a multiple of 10 ms.</p>																				
SOUT	<p>Stop Streaming</p> <p>Turn off streaming output.</p>																				
DISP(?) { <i>i</i> }	<p>Display</p> <p>Set (query) the display selection {to <i>i</i>}.</p> <p>Valid display codes are:</p> <table border="1" style="margin-left: 20px; border-collapse: collapse;"> <thead> <tr> <th style="border-right: 1px solid black; padding: 2px;"><i>i</i></th> <th style="padding: 2px;">Display</th> </tr> </thead> <tbody> <tr> <td style="border-right: 1px solid black; padding: 2px;">0</td> <td style="padding: 2px;"><i>Units</i></td> </tr> <tr> <td style="border-right: 1px solid black; padding: 2px;">1</td> <td style="padding: 2px;"><i>Units</i>+<i>A_{OUT}</i></td> </tr> <tr> <td style="border-right: 1px solid black; padding: 2px;">2</td> <td style="padding: 2px;"><i>Units</i>+<i>Value</i></td> </tr> <tr> <td style="border-right: 1px solid black; padding: 2px;">3</td> <td style="padding: 2px;"><i>A_{OUT}</i></td> </tr> <tr> <td style="border-right: 1px solid black; padding: 2px;">4</td> <td style="padding: 2px;"><i>Freq. (Hz)</i></td> </tr> <tr> <td style="border-right: 1px solid black; padding: 2px;">5</td> <td style="padding: 2px;"><i>Offset</i></td> </tr> <tr> <td style="border-right: 1px solid black; padding: 2px;">6</td> <td style="padding: 2px;"><i>Phase (deg.)</i></td> </tr> <tr> <td style="border-right: 1px solid black; padding: 2px;">7</td> <td style="padding: 2px;"><i>Value</i>–<i>Offset</i></td> </tr> <tr> <td style="border-right: 1px solid black; padding: 2px;">8</td> <td style="padding: 2px;"><i>Value</i></td> </tr> </tbody> </table>	<i>i</i>	Display	0	<i>Units</i>	1	<i>Units</i> + <i>A_{OUT}</i>	2	<i>Units</i> + <i>Value</i>	3	<i>A_{OUT}</i>	4	<i>Freq. (Hz)</i>	5	<i>Offset</i>	6	<i>Phase (deg.)</i>	7	<i>Value</i> – <i>Offset</i>	8	<i>Value</i>
<i>i</i>	Display																				
0	<i>Units</i>																				
1	<i>Units</i> + <i>A_{OUT}</i>																				
2	<i>Units</i> + <i>Value</i>																				
3	<i>A_{OUT}</i>																				
4	<i>Freq. (Hz)</i>																				
5	<i>Offset</i>																				
6	<i>Phase (deg.)</i>																				
7	<i>Value</i> – <i>Offset</i>																				
8	<i>Value</i>																				

2.4.5 Post-detection processing commands

FRST	Filter Reset Reset the post-detection filter.
------	--

TCON(?) {i}	Time Constant Set (query) the time constant for the post-detection filter { to i}.
-------------	---

Valid time constant codes are:

<i>i</i>	Time Constant
-1	filter off (sync only)
0	0.3 s
1	1 s
2	3 s
3	10 s
4	30 s
5	100 s
6	300 s

PHLD(?) {z}	Phase Hold Set (query) the phase hold mode {to z=(OFF 0, ON 1)}. Forces the resistance calculation to assume zero phase.
-------------	--

2.4.6 Calibration curve commands

DTEM(?) {z}	Display Temperature Set (query) the display temperature mode {to z=(OFF 0, ON 1)}. When ON, the SIM921 display for <i>Value</i> will be in temperature units instead of resistance.
-------------	---

ATEM(?) {z}	Analog Output Temperature Set (query) the analog output temperature mode {to z=(OFF 0, ON 1)}. When ON, the SIM921 generates an analog output proportional to temperature deviation instead of resistance deviation. Also, the display units for <i>Value-Offset</i> and <i>Offset</i> are set with ATEM.
-------------	--

CURV(?) {i}	Sensor Calibration Curve Set (query) the selected sensor calibration curve {to i}. Valid curve numbers are 1, 2, and 3. A curve number may be selected with CURV even if no corresponding curve has been loaded into the SIM921.
-------------	---

CINI(?) <i>i</i> { <i>z,s</i> }	<p>Initialize Sensor Calibration</p> <p>Initialize sensor calibration curve $i=(1, 2, \text{ or } 3)$.</p> <p>The set form of the command, CINI <i>i,z,s</i>, erases the old contents of curve <i>i</i>. The second parameter $z=(\text{LINEAR } 0, \text{ SEMILOGT } 1, \text{ SEMILOGR } 2, \text{ LOGLOG } 3)$ defines the sensor curve format. The third parameter <i>s</i> is an arbitrary identification string for this sensor calibration curve. This string can consist of any non-blank characters <i>except</i> the comma “,” or semicolon “;”, and can be up to 15 characters in length. The leading 5 characters will be displayed on the SIM921 front panel when the curve is selected, within the limitations of the seven-segment display hardware.</p> <p>The query form of the command, CINI? <i>i</i>, returns the following response:</p> <p>⟨format⟩, ⟨serial⟩, <i>n</i></p> <p>where ⟨format⟩ is the calibration curve format (same as <i>z</i> above), ⟨serial⟩ is the full identification string for the curve, and <i>n</i> is the number of points currently stored in the curve.</p>
CAPT <i>i,f,g</i>	<p>Add Point to Sensor Calibration</p> <p>Add a new point to sensor calibration curve <i>i</i>. <i>f</i> is the raw sensor value (in either ohms or $\log_{10}(\text{ohms})$, depending on curve format), and <i>g</i> is the corresponding temperature value (in either kelvin or $\log_{10}(\text{kelvin})$, again depending on curve format).</p> <p>Note that curve points <i>must</i> be added in increasing order of sensor value <i>f</i>.</p>
CAPT? <i>i,j</i>	<p>Query Point in Sensor Calibration</p> <p>Query the value of sensor calibration curve <i>i</i>, entry point <i>j</i>.</p> <p>The response is ⟨sensor⟩, ⟨temperature⟩, where ⟨sensor⟩ is the raw sensor value (in either ohms or $\log_{10}(\text{ohms})$, depending on curve format), and ⟨temperature⟩ is the corresponding temperature value (in either kelvin or $\log_{10}(\text{kelvin})$, again depending on curve format).</p>

2.4.7 Autoranging commands

AGAI(?) {z}	<p>Autorange Gain</p> <p>Set (query) autoranging of gain {to z=(OFF 0, ON 1)}. When autoranging gain, the SIM921 will optimize signal-to-noise for the current and voltage measurement channels. After autoranging gain completes, the SIM921 automatically turns AGAI OFF.</p>
-------------	---

ADIS(?) {z}	<p>Autorange Display</p> <p>Set (query) autoranging of the display {to z=(OFF 0, ON 1)}.</p>
-------------	--

2.4.8 Autocalibration command

ACAL	<p>Autocalibration</p> <p>Initiate the internal autocalibration cycle (takes approximately 3 minutes). Remote commands will not be processed further until the autocalibration is completed.</p>
------	--

2.4.9 Setpoint and analog output commands

RSET(?) {f}	<p>Resistance Setpoint</p> <p>Set (query) the resistance setpoint {to f ohms}. This is the “offset” value used in generating the analog output when ATEM OFF.</p>
-------------	---

TSET(?) {f}	<p>Temperature Setpoint</p> <p>Set (query) the temperature setpoint {to f kelvin}. This is the “offset” value used in generating the analog output when ATEM ON.</p>
-------------	--

VOHM(?) {f}	<p>Analog Output Scale (V/Ω)</p> <p>Set (query) the analog output scale { to f V/Ω}. This is the scale used when ATEM OFF.</p>
-------------	--

VKEL(?) {f}	<p>Analog Output Scale (V/K)</p> <p>Set (query) the analog output scale { to f V/K}. This is the scale used when ATEM ON.</p>
-------------	---

AMAN(?) {z}	<p>Analog Output Manual Mode</p> <p>Set (query) the analog output manual mode {to z=(OFF 0, ON 1)}. When ON, the analog output is simply equal to the AOUT value; when OFF, the output is the scaled and offset measurement result.</p>
-------------	---

AOUT(?) {f}	Analog Output Manual Value Set (query) the Analog Output Manual value {to <i>f</i> volts}. This is the output value when AMAN ON.
-------------	--

2.4.10 Interface commands

*RST	Reset Reset the SIM921 to default configuration. *RST executes the following commands: <ul style="list-style-type: none"> • <code>FREQ 10</code> • <code>RSET 1.0</code> • <code>TSET 1.0</code> • <code>VOHM 1.0</code> • <code>VKEL 1.0</code> • <code>EXCI 1</code> • <code>RANG 6</code> • <code>TCON 1</code> • <code>MODE PASSIVE</code> • <code>ADIS ON</code> • <code>TPER 1000</code> • <code>TOKN OFF</code>
*IDN?	Identify Read the device identification string. The identification string is formatted as: <code>Stanford_Research_Systems,SIM921,s/n*****,ver#.#</code> where <code>*****</code> is the 6-digit serial number, and <code>#. #</code> is the firmware revision level.
*TST?	Self Test There is no self-test function. *TST will always return 0.

*OPC(?)	<p>Operation Complete</p> <p>Operation Complete. Sets the OPC flag in the ESR register.</p> <p>The query form *OPC? writes a 1 in the output queue when complete, but does not affect the ESR register.</p>																		
CONS(?) {z}	<p>Console Mode</p> <p>Set (query) the console mode {to z=(OFF 0, ON 1)}.</p> <p>CONS causes each character received at the input buffer to be copied to the output queue.</p> <p>At power-on and Device-Clear, CONS is set to OFF.</p>																		
LEXE?	<p>Execution Error</p> <p>Query the last execution error code. Valid codes are:</p> <table border="1" data-bbox="560 892 1161 1228"> <thead> <tr> <th>Value</th> <th>Definition</th> </tr> </thead> <tbody> <tr> <td>0</td> <td>No execution error since last LEXE?</td> </tr> <tr> <td>1</td> <td>Illegal value</td> </tr> <tr> <td>2</td> <td>Wrong token</td> </tr> <tr> <td>3</td> <td>Invalid bit</td> </tr> <tr> <td>16</td> <td>Uninitialized curve</td> </tr> <tr> <td>17</td> <td>Curve full</td> </tr> <tr> <td>18</td> <td>Curve point out-of-order</td> </tr> <tr> <td>19</td> <td>Curve point past end</td> </tr> </tbody> </table>	Value	Definition	0	No execution error since last LEXE?	1	Illegal value	2	Wrong token	3	Invalid bit	16	Uninitialized curve	17	Curve full	18	Curve point out-of-order	19	Curve point past end
Value	Definition																		
0	No execution error since last LEXE?																		
1	Illegal value																		
2	Wrong token																		
3	Invalid bit																		
16	Uninitialized curve																		
17	Curve full																		
18	Curve point out-of-order																		
19	Curve point past end																		

LCME?

Command Error

Query the last command error code. Valid codes are:

Value	Definition
0	No execution error since last LCME?
1	Illegal command
2	Undefined command
3	Illegal query
4	Illegal set
5	Missing parameter(s)
6	Extra parameter(s)
7	Null parameter(s)
8	Parameter buffer overflow
9	Bad floating-point
10	Bad integer
11	Bad integer token
12	Bad token value
13	Bad hex block
14	Unknown token

LBTN?

Button

Query the last button-press code. Valid codes are:

Value	Definition
0	no button pressed since last LBTN?
1	[Display ▼]
2	[Display ▲]
3	[Set ▼]
4	[Set ▲]
5	undef
6	[Excite ▼]
7	[Excite ▲]
8	[Range ▼]
9	[Range ▲]
10	[Autocal]
11	[Autorange]
12	[Mode]
13	[Time Const. ▼]
14	[Time Const. ▲]

TOKN(?) {z} Token Mode

Set (query) the Token Query mode {to z=(**OFF 0**, **ON 1**)}.

If TOKN ON is set, then queries to the SIM921 that return tokens will return the text keyword; otherwise they return the decimal integer value.

An interesting illustration of this is the observation that the only possible responses to the TOKN? query are ON and 0.

At power-on, TOKN is set to OFF.

TERM(?) {z} Response Termination

Set (query) the <term> sequence {to z=(**NONE 0**, **CR 1**, **LF 2**, **CRLF 3**, **LFCR 4**)}. The <term> sequence is appended to all query responses sent by the module, and is constructed of ASCII character(s) 13 (carriage return) and 10 (line feed). The token mnemonic gives the sequence of characters.

At power-on, TERM is set to CRLF.

2.4.11 Status commands

The Status commands query and configure registers associated with status reporting of the SIM921.

***STB? [i]** Status Byte

Reads the Status Byte register [bit *i*].

The *STB? query causes the –STATUS signal to be released if asserted. (See also PSTA)

***SRE(?) [i,] {j}** Service Request Enable

Set (query) the Service Request Enable register [bit *i*] {to *j*}.

***CLS** Clear Status

*CLS immediately clears the ESR, CESR, and OVSR.

PSTA(?) {z}	<p>Pulsed Status Mode</p> <p>Set (query) the Pulse –STATUS Mode {to z=(OFF 0, ON 1)}.</p> <p>When PSTA ON is set, any new service request will only <i>pulse</i> the –STATUS signal low (for a minimum of 1 μs). The default behavior is to latch –STATUS low until a *STB? query is received.</p> <p>On reset, PSTA is set to OFF.</p>
*ESR? [i]	<p>Standard Event Status</p> <p>Reads the Standard Event Status Register [bit i].</p> <p>Upon executing *ESR?, the returned bit(s) of the ESR register are cleared.</p>
*ESE(?) [i,] {j}	<p>Standard Event Status Enable</p> <p>Set (query) the Standard Event Status Enable Register [bit i] {to j}.</p>
CESR? [i]	<p>Communication Error Status</p> <p>Query Communication Error Status Register [for bit i].</p> <p>Upon executing a CESR? query, the returned bit(s) of the CESR register are cleared.</p>
CESE(?) [i,] {j}	<p>Communication Error Status Enable</p> <p>Set (query) Communication Error Status Enable Register [for bit i] {to j}</p>
OVCR? [i]	<p>Overload Condition</p> <p>Query Overload Condition Register [for bit i].</p>
OVSR? [i]	<p>Overload Status</p> <p>Query Overload Status Register [for bit i].</p> <p>Upon executing a OVSR? query, the returned bit(s) of the OVSR register are cleared.</p>
OVSE(?) [i,] {j}	<p>Overload Status Enable</p> <p>Set (query) Overload Status Enable Register [for bit i] {to j}</p>

2.5 Status Model

The SIM921 status registers follow the hierarchical IEEE–488.2 format. A block diagram of the status register array is given in Figure 2.1.

There are three categories of registers in the SIM921 status model:

- Condition Registers : These read-only registers correspond to the real-time condition of some underlying physical property being monitored. Queries return the latest value of the property, and have no other effect. Condition register names end with CR.
- Event Registers : These read-only registers record the occurrence of defined events. When the event occurs, the corresponding bit is set to 1. Upon querying an event register, any set bits within it are cleared. These are sometimes known as “sticky bits,” since once set, a bit can only be cleared by reading its value. Event register names end with SR.
- Enable Registers : These read/write registers define a bitwise mask for their corresponding event register. If any bit position is set in an event register while the same bit position is also set in the enable register, then the corresponding summary bit message is set. Enable register names end with SE.

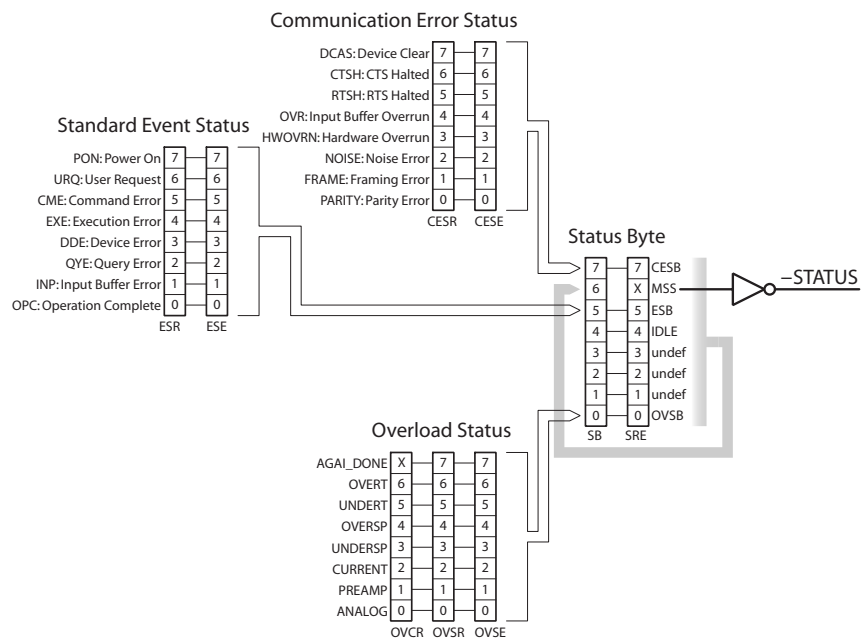

Figure 2.1: Status Register Model for the SIM921 AC Resistance Bridge.

2.5.1 Status Byte (SB)

The Status Byte is the top-level summary of the SIM921 status model. When masked by the Service Request Enable register, a bit set in the Status Byte causes the -STATUS signal to be asserted on the rear-panel SIM interface connector.

Typically, -STATUS remains asserted (low) until a *STB? query is received, at which time -STATUS is deasserted (raised)¹. After clearing the -STATUS signal, it will only be re-asserted in response to a *new* status-generating condition.

Weight	Bit	Flag
1	0	OVSB
2	1	undef (0)
4	2	undef (0)
8	3	undef (0)
16	4	IDLE
32	5	ESB
64	6	MSS
128	7	CESB

OVSB : Overload Status Summary Bit. Indicates whether one or more of the enabled flags in the Overload Status Register has become true.

IDLE : Indicates that the input buffer is empty and the command parser is idle. Can be used to help synchronize SIM921 query responses.

ESB : Event Status Bit. Indicates whether one or more of the enabled events in the Standard Event Status Register is true.

MSS : Master Summary Status. Indicates whether one or more of the enabled status messages in the Status Byte register is true. Note that while -STATUS is released by the *STB? query, MSS is only cleared when the underlying enabled bit message(s) are cleared.

CESB : Communication Error Summary Bit. Indicates whether one or more of the enabled flags in the Communication Error Status Register has become true.

Bits in the Status Byte are *not* cleared by the *STB? query. These bits are only cleared by reading the underlying event registers, or by clearing the corresponding enable registers.

¹ but see the PSTA command

2.5.2 Service Request Enable (SRE)

Each bit in the SRE corresponds one-to-one with a bit in the SB register, and acts as a bitwise AND of the SB flags to generate the MSS bit in the SB and the -STATUS signal. Bit 6 of the SRE is undefined—setting it has no effect, and reading it always returns 0. This register is set and queried with the `*SRE(?)` command.

This register is cleared at power-on.

2.5.3 Standard Event Status (ESR)

The Standard Event Status register consists of 8 event flags. These event flags are all “sticky bits” that are set by the corresponding event, and cleared only by reading or with the `*CLS` command. Reading a single bit (with the `*ESR? i` query) clears only bit i .

Weight	Bit	Flag
1	0	OPC
2	1	INP
4	2	QYE
8	3	DDE
16	4	EXE
32	5	CME
64	6	URQ
128	7	PON

OPC : Operation Complete. Set by the `*OPC` command.

INP : Input buffer Error. Indicates data has been discarded from the input buffer.

QYE : Query Error. Indicates data in the output queue has been lost.

DDE : Device Dependent Error. Undefined for SIM921.

EXE : Execution Error. Indicates an error in a command that was successfully parsed. Out-of-range parameters are an example. The error code can be queried with `LEXE?`.

CME : Command Error. Indicates a parser-detected error. The error code can be queried with `LCME?`.

URQ : User Request. Indicates a front-panel button was pressed.

PON : Power On. Indicates that an off-to-on transition has occurred.

2.5.4 Standard Event Status Enable (ESE)

The ESE acts as a bitwise AND with the ESR register to produce the single bit ESB message in the Status Byte Register (SB). It can be set and queried with the `*ESE(?)` command.

This register is cleared at power-on.

2.5.5 Communication Error Status (CESR)

The Communication Error Status register consists of 8 event flags; each of which is set by the corresponding event, and cleared only by reading or with the *CLS command. Reading a single bit (with the CESR? *i* query) clears only bit *i*.

Weight	Bit	Flag
1	0	PARITY
2	1	FRAME
4	2	NOISE
8	3	HWOVRN
16	4	OVR
32	5	RTSH
64	6	CTSH
128	7	DCAS

PARITY : Parity Error. Set by serial parity mismatch on incoming data byte.

FRAME : Framing Error. Set when an incoming serial data byte is missing the STOP bit.

NOISE : Noise Error. Set when an incoming serial data byte does not present a steady logic level during each asynchronous bit-period window.

HWOVRN : Hardware Overrun. Set when an incoming serial data byte is lost due to internal processor latency. Causes the input buffer to be flushed, and resets the command parser.

OVR : Input buffer Overrun. Set when the input buffer is overrun by incoming data. Causes the input buffer to be flushed, and resets the command parser.

RTSH : Undefined for the SIM921. Command Error. Indicates a parser-detected error.

CTSH : Undefined for the SIM921.

DCAS : Device Clear. Indicates the SIM921 received the Device Clear signal (an RS-232 <break>). Clears the input buffer and output queue, and resets the command parser.

2.5.6 Communication Error Status Enable (CESE)

The CESE acts as a bitwise AND with the CESR register to produce the single bit CESB message in the Status Byte Register (SB). It can be set and queried with the CESE(?) command.

This register is cleared at power-on.

2.5.7 Overload Status (OVCR)

The Overload Condition Register consists of 7 single-bit monitors of condition events within the SIM921. Bits in the OVCR reflect the real-time values of their corresponding signals. Reading the entire register, or individual bits within it, does not affect the OVCR.

Weight	Bit	Flag
1	0	ANALOG
2	1	PREAMP
4	2	CURRENT
8	3	UNDERSP
16	4	OVERSP
32	5	UNDERT
64	6	OVERT
128	7	undef (0)

ANALOG : Analog overload. A signal amplifier was saturated.

PREAMP : The front-end preamp saturated.

CURRENT : The excitation current exceeded 12 mA (saturation).

UNDERSP : The excitation servo fell below 90 % of the commanded excitation.

OVERSP : The excitation servo exceeded 110 % of the commanded excitation.

UNDERT : Calibration curve underflow ($R < R_{\min}$).

OVERT : Calibration curve overflow ($R > R_{\min}$).

2.5.8 Overload Status (OVSR)

The Overload Status Register consists of (latching) event flags that correspond one-to-one with the bits of the OVCR (see above). Upon the transition $0 \rightarrow 1$ of any bit within the OVCR, the corresponding bit in the OVSR becomes set.

Bits in the OVSR are unaffected by the $1 \rightarrow 0$ transitions in the OVCR, and are cleared only by reading or with the *CLS command. Reading a single bit (with the OVSR? *i* query) clears only bit *i*.

An additional bit, AUTOGAIN_DONE (weight=128, bit=7) is defined in the OVSR to signal completion of an autorange gain cycle.

2.5.9 Overload Status Enable (OVSE)

The OVSE acts as a bitwise AND with the OVSR register to produce the single bit OVSB message in the Status Byte Register (SB). It can be set and queried with the OVSE(?) command.

This register is cleared at power-on.